



ज्ञान-विज्ञान विमुक्तये



অসম চৰকাৰ



GOVERNMENT OF ASSAM



বজা মায়াং

মায়াং আঞ্চলিক

মহাবিদ্যালয়

মৰিগাঁও : অসম

MAYANG ANCHALIK COLLEGE

PROSPECTUS

Academic Session- 2024-25

MAYANG ANCHALIK COLLEGE

(NAAC Accredited with A+ Grade)

Rajamayang, Morigaon, Assam

Ph- 9435064252, 7002339541

Email : mayanganchalikcollege@gmail.com

Website : www.mayanganchalikcollege.org.in

mayanganchalikcollegeofficial

MayangAnchalik

mayanganchalikcollege

Our Tribute to the Torchbearer Soul



Dipan Chandra Nath
(1935- 2013)

*'Education is the most
powerful weapon
which you can use to
change the world'*

-Nelson Mandela

DIPAN CHANDRA NATH MEMORIAL LECTURE

Mayang Anchalik College is going to organize a memorial lecture in fond memory of *Mayong Khanikar* Late Dipan Chandra Nath, the founder secretary of Mayang Anchalik College GB, every year from this academic session. For this lecture eminent personalities of the state will be invited to acquaint the students with various contemporary issues.



PRINCIPAL'S MESSAGE



My Dear Students Greetings from Mayang Anchalik College...

Education makes you powerful and this power helps you to reinvent yourself leading you to shape your future and influence the world. True leader is the one who learns how to change through learning

You are welcome to Mayang Anchalik College, Rajamayang, Morigaon, Assam, one of the most prestigious colleges for Arts and Vocational Courses affiliated to Gauhati University that provides you the space to ignite your imagination and inspire quest for learning. The under graduate programs focused on bridging the gap between graduate expectations and employment reality. With a blend of curricular, co-curricular and value added activities every student is encouraged to explore and reach his dreams. The teachers who are very homely and friendly you to achieve your desired goal. To support this transformational engagement, the College campus spreads a canvas large with right tools – spacious class rooms, a smart classroom, healthy teacher-students relationship, computer lab with wi-fi facility, rich library, centralized e-library, spacious playground, indoor stadium, gymnasium, boys and girls hostels, heritage museum, eco-friendly canteen, medicinal plant garden, vegetable garden and frequent industry interactions. The College is located in a pollution free area with full of greenery around. The College has been accredited A+ Grade by NAAC in its first cycle.

Come, learn, discover yourself, mould your dreams and enlighten the world with knowledge.

(DR RANJIT KUMAR KALITA)
Principal
Mayang Anchalik College

NO ENTRY FOR VEHICLES
Entry of any Vehicle inside the College
Campus is strictly Prohibited
Mayang Anchalik College



राष्ट्रीय मूल्यांकन एवं प्रत्यायन परिषद
विश्वविद्यालय अनुदान आयोग का स्वायत्त संस्थान
NATIONAL ASSESSMENT AND ACCREDITATION COUNCIL
An Autonomous Institution of the University Grants Commission

Certificate of Accreditation

*The Executive Committee of the
National Assessment and Accreditation Council
is pleased to declare
Mayang Anchalik College
Vill. Rajamayang, Dist. Morigaon, affiliated to Gauhati University,
Assam as
Accredited
with CGPA of 3.37 on four point scale
at A⁺ grade
valid up to December 12, 2027*

Date : December 13, 2022



*S.C. Sharma
Director*

EC(SC)/135/1st Cycle/ASCOGN107808

OUR VISION

To Achieve Academic Excellence with all sections of the society.



OUR MISSION

To generate enriched human being with academic, spiritual, ethical, socio-cultural and scientific knowledge & skill.



OUR CORE VALUES

Strive for Excellence

Unifying in Character

Social Responsibility



MAYANG ANCHALIK COLLEGE: A BRIEF PROFILE

Mayang Anchalik College, a Degree (Arts) College, which has been accredited A+ Grade by NAAC in 2022 in its first cycle of inspection. The College was established in 1992, in the village Rajamayang, is the only seat of higher learning in the western part of the district of Morigaon, Assam. The College is the product of hard works and dedication of the common people with the visionary leadership and commitment of the academic luminaries of this region. The institution, which came into being in an economically and educationally backward and flood-prone region like Mayang, recently the college celebrated its silver Jubilee on August 2017.

The College is permanently affiliated to the University of Gauhati. The Core Subjects offered by the college are: Economics, History, Political Science, Education, English and Assamese. Major Courses are available in Economics, History, Political Science, Education and Assamese. The College has been included under sections 2(f) & 12 (B) of the UGC Act 1956. Started with a few copies of books in its library, the College has now a holding of over 14,000 collections of both textbooks and references in its central library and has subscribed to many journals and newspapers. Now, the College is the Centre of Excellence in imparting and expanding education among the rural poor students. The College library is dedicated to the honourable founder secretary of the College Late Dipan Ch. Nath.

Mayang region, previously known for its mystic quality, is a growing urban area which is one-hour drive from Guwahati. What attracts more is the enthralling geographic location of Mayang Anchalik College between the mighty Brahmaputra on the North and the Pobitora Wildlife Sanctuary on the south. Fringed by beautiful lush green countryside, the sprawling campus of the College always provides an idyllic academic atmosphere at the College. Situated at a distance of 42 Km from Morigaon College, 35 Km from Jagiroad College, 35 Km from Dimoria College and 33 Km from Narengi Anchalik College, Guwahati, Mayang Anchalik College is a preferred destination of higher education for the rural poor students. All roads to the College are pacca (black topping). Since its inception, the College has been rendering quality higher education to the students, following participatory methods in a friendly and learner-centred atmosphere.



ADMINISTRATIVE BODY

Governing Body (GB) administers all academic and administrative affairs of the College. GB is the Chief Executive Body of the College. Discretionary powers are vested upon the GB and the Principal of the College who controls and undertakes responsibility for the maintenance of standard of education, inter-departmental co-ordination, examination, and research and infrastructure development of the College. Mayang Anchalik College has its own Administrative Block, Academic Block, well-equipped Library, Play ground, Indoor Stadium and a Women's Hostel, Canteen and proper sanitation within the campus.

THE COLLEGE EMBLEM

The Emblem stands for multi-dimensional meaning that suggests a march towards excellence through proper education. The blooming lotus on the muddy water is suggestive of the Mayang Anchalik College, the only temple of higher learning in the entire locale that has grown up in an economically and educationally backward and flood-prone region like Mayang, disseminating its fragrance of knowledge. The rising sun symbolizes the College's unyielding stride from the darkness of ignorance to the light of wisdom. The line "TAMOSHO MAA JYOTIRGAMAYA" the motto taken from the Upanishad means a prayer to the Almighty to bring us to light from darkness. The emblem and the motto emphasize the sanctity of knowledge which is relevant to all ages. The emblem transcends the barrier of caste, creed, and religion.



PROGRAMMES AND COURSES OFFERED

Mayang Anchalik College has implemented Four Year Under Graduate Programme (FYUGP) initiated by Gauhati University following the National Education Policy 2020. The Programme is developed considering the academic needs of the students in present educational scenerio.

Mayang Anchalik College offers two types of Bachelor's Degrees.

- 1. Degree in Stream (Arts)**
- 2. Degree in Discipline**

Degree in Stream relates to Arts Stream.

Degree in Discipline relates to two Vocational Courses-

- 1. B. Voc. in Tourism and Travel Management (TTM)**
- 2. B. Voc. in Food Processing and Quality Management (FPQM)**

Students of Mayang Anchalik College can study following subjects in Arts stream as Major Subjects:

**Assamese
Economics
Political Science
Education
History**

The College offers Minor Courses in following subjects:

**English
Assamese
Economics
Political Science
Education
History**

The Common Courses will be offered as per the syllabus provided by Gauhati University.

CERTIFICATE COURSES

Mayang Ancahlik College offers the following certificate courses:-

- Content Writing
- Confidently Speaking Skill
- Writing Bio-Data
- Mental Health and Hygiene
- Creativity and Students
- Khol Badan (Folk Instrument)
- Proof Reading
- Psychological Testing
- Democracy in India & its various perspective
- 73rd Ammendments of the Constitution of India
- Constitution and its Nature
- Spoken English
- Jaquard Handloom
- Tourism Management
- Folk Dance (Bihu)
- Flute Music
- News Paper Editing
- Manu and Manusmriti
- Kautilya and Saptanga Theory
- Human Rights
- Still Photography
- Fine Arts
- Community Journalism
- Banking and Finance
- Role of Bank in Economic development
- Management of Small Scale and Cottage Industries
- Agricultural Marketing
- Folk Instruments (Dhol Badan)
- Stage Performance
- Content Development
- The Right to information Act, 2005
- Creative Writing
- Short Story Writing
- Basics of Tourism Geography
- Project Writing
- Facing an Interview
- Health Literacy
- Museum Management
- Developmental Psychology
- Sustainable Tourism
- Mental Health, Sanitation, Hygiene
- Fundamentals of food and nutrition
- Preamble of the Constitution
- Democracy and its classification
- 74th Amendment of the Constitution

Skill courses

Pradhan Mantri Kaushal Vikash Yojana (PMKVY) 4.0

Under Tourism and Hospitality Sector Skill Council

1. Counter Sales Executive
2. Front Office Management
3. Housekeeping

Under Food processing Sector Skill Council-

1. Pickle making Technician.
2. Jam, Jelly and Ketchup Processing Technician.
3. Fruit pulp processing technician.
4. Plant Biscuit Production Specialist.



PM Vishwakarma Yojana:

- Trade :
1. Mason(Rajmistri),
 2. Fishing Net Maker
 3. Tailor(Darzi)

Special Coaching Courses

Mayang Anchalik College have introduced the following special coaching courses:-

Coaching course for NET/SLET Examinations.

Coaching course for TET Examination.

Coaching Course for Competitive Examinations like Bank, LIC, Railways etc.



INTRODUCTION TO THE SYLLABUS

The Four-Year Undergraduate Programme (FYUGP) of Gauhati University is as per UGC's Curricular Framework, published in November 2022. The course structure of FYUGP is built on the Choice-Based Credit System (CBCS). Though, the FYUGP is basically a CBCS, it is radically different from the courses running under CBCS. Namely, it does not differentiate between so-called Honours and Pass courses existing under CBCS. Basically, the FYUGP is based on the system of education under Liberal Arts.

SALIENT FEATURES

Structure-wise, the present Bachelor's Degree programme under the CBCS is a 3-year degree programme at the end of which, a student will be awarded a Bachelor's Degree in Arts, Science, or Commerce. One can also have a Bachelor's of Vocation degree, being run in some colleges, which in short form known as the BVoc degree. The two systems – Bachelor's Course under CBCS and Bachelor's Course under the FYUGP of NEP are different in the following ways.

DURATION

While under CBCS, one has a 3-year degree programme, under the NEP's FYUGP, it is a 4-year degree programme with multiple Exits and Entries.

HONOURS AND MAJOR

Under the CBCS, we either have Bachelor's Degree (Honours) or a regular Bachelor's Degree. In FYUGP, we get a Bachelor's Degree with Major after 3 years and a degree with Major & Honours after 4 year.

PROGRESSION

If a student exits the FYUGP after 3 years, s/he will need to take admission into the first year of a Master's programme, which is a 2-year degree programme. However, if a student fully completes an FYUGP, s/he needs to take admission into the second year of a Master's programme and needs to complete only one year to get a Master's Degree. Under CBCS, there was no such pathways.

PROGRESSION TO DOCTORAL STUDIES

Once a student takes admission into a Master's programme either after 3 years of the Bachelor's programme or after FYUGP, one will be able to take admission into a Doctoral programme leading to the Degree of PhD. However, if a student is exceptionally good, one can directly take admission into a Doctoral programme right after the FYUGP, bypassing the Master's programme.

Four Year Under Graduate Programme

FYUGP Progression

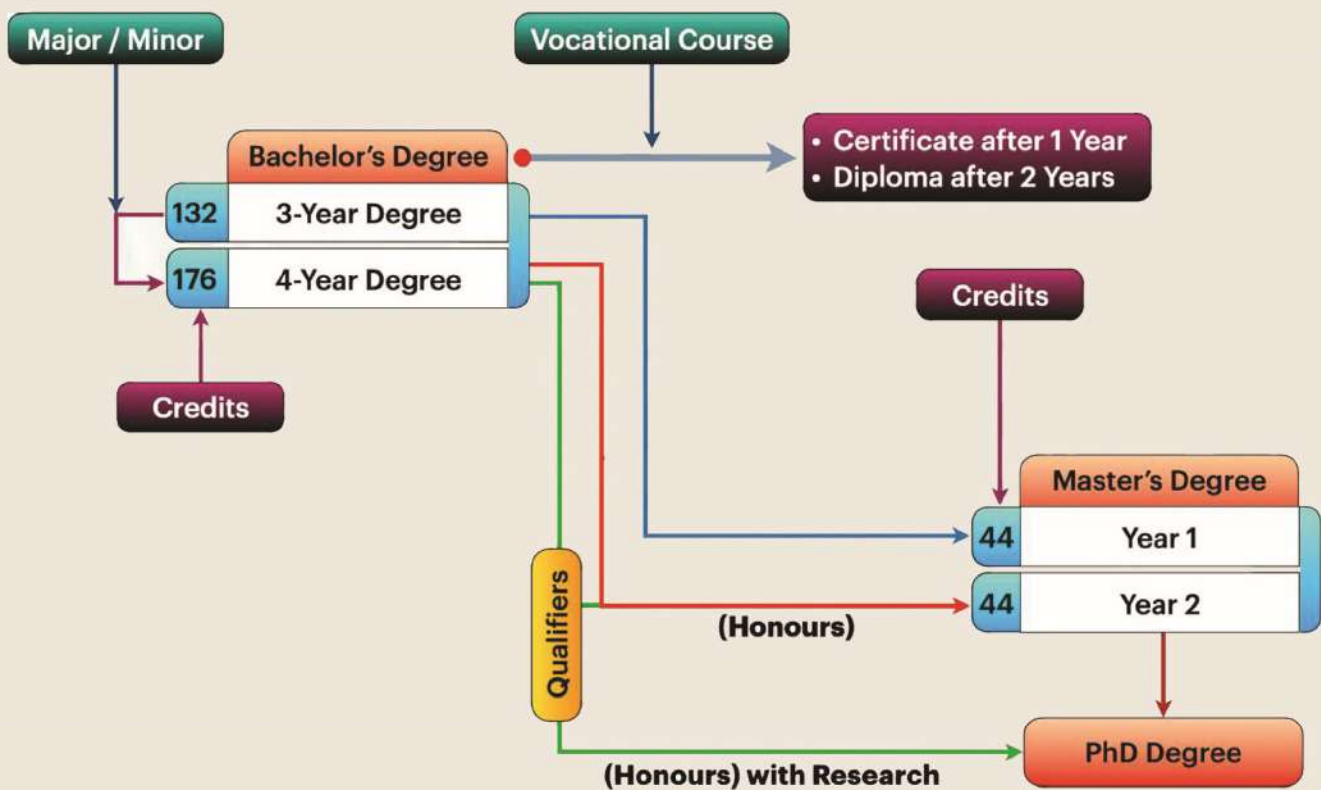

PROGRESSION AND EXITS

The progression and exits during the whole course structure is given below.

(a) After 1 Year

One can exit just after one-year. In this case, the student will have to complete one extra Vocational / Skill course (Exit Course) of 4 credits and can exit the programme. **The student will get a Certificate.** The minimum total credit requirements is 44 (and 4 credit extra for the exit Vocational / Skill course).

(b) After 2 Years

One can exit the programme after two-year course as well. In this case, the student will have to complete one extra Vocational / Skill course of 4 credits and can exit the programme. **The student will get a Diploma.** The minimum total credit requirements is 84 (and 4 credits extra for the exit Vocational / Skill course).

(c) After 3 Years

If a student completes 3 years, s/he can exit the programme. In this case the student will get a **Bachelor's Degree.** The minimum total credit requirements is 120.

(d) After 4 Years

After completion of 4 years, the student gets either a Bachelor's Degree (Honours) or a **Bachelor's Degree (Honours) with Research.** The minimum total credit requirements is 160. It should be noted that any certificate / diploma / degree is awarded only if the student clears (i.e. passes) all the required

HOW DIFFERENT ARE THE COURSES?

The major differentiator between the FYUGP and the existing CBCS is the student's ability to study different subjects of choice and also the ability to switch between subjects. Basically, there are two parts of a course under the FYUGP – (a) Core Courses and (b) Common Courses. As the name suggests, different students study different core courses and all students study the common courses. Below, we describe what you will study in different parts of the programme.

First Year (Semester I & II)

In the first year, one studies three different core subjects – one paper of each subjects per semester. Besides, one needs to study a host of common subjects that we have designed as per UGC's Curricular Framework. Details of these courses are described in this booklet.

Second Year (Semester III & IV)

Semester III

In the third semester, one will usually continue with the same core subjects that have already been chosen in the first year and again study some common subjects. In the third semester, one will also take a step forward to study the favourite subject by declaring one of the core subjects as a Major subject and other two as Minors. However, the structure of the programme remains same as in first & second semesters.

Semester IV

From Semester IV onwards, one will primarily study the Major subject by taking at least four papers, some of which may be elective depending on the subject concerned.

As the programme structure in the third semester is same as the first & second semesters, one will have the option of changing the Major in fourth semester to any one of the other two Minors as well, even if one has already declared a Major in the third semester. However this has the condition that the new Major subject of choice has vacancy.

Key Points:

If you would like to change a Minor subjects in the third semester, you can change with the following limitations:

1. You will be able to change a subject, provided the new subject can accommodate you. This can be a problem with science subjects as they need to ensure laboratory space for each student.
2. Besides, as you have already abandoned the first year time studying a subject which you no longer want to continue, you will need to use your free credits to compensate for the new subject. This will be more clear once you see the examples we have given afterwards.

Third Year (Semester V and VI):

In the third year, one will continue to study the Major subject to complete a full set of 15 papers in Majors.

Fourth Year:

If one intends to progress to the fourth year, s/he will be devoting the time in studying advanced courses which will be at the level of initial Master's degree papers. Besides, one will also have the opportunity of engaging into research work with the faculty members.

Besides the above, there are some more unique features of the FYUGP. They are

Open Core Credits:

From fourth to sixth semester, one will have time for 4 optional open core credits per semester, which one can utilise to study either of the Major or two Minors. They can also come handy, if one had changed a Minor subject in between.

Double Major:

If a student is ready to do some more hard work, s/he can take some extra online courses (from designated sources only) related to the Minors and can then convert one of the Minors to a second Major by the time one completes 3 / 4 years of study. This is over and above the first Major. In this case, one will have a Bachelor's Degree with Double Major.

FYUGP DEGREES & COURSE STRUCTURES

The FYUGP at GU is designed to offer two types of Bachelor's Degrees to the students at the end of the successful completion of the programme—(i) Bachelor's Degree in a Stream and (ii) Bachelor's Degree in a Discipline. The word stream here refers to Arts, Science, Commerce, and Management. In case of a degree in a stream, the student studies a multitude of different subjects, usually mixing different disciplines, which leads to a truly multidisciplinary degree. While in case of a degree in a discipline, the student is confined to a certain sets of disciplines. However, in both cases, the student studies equal number of courses (i.e. papers) — so there is no weightage of any kind to either of the two types of degrees. For both the types of degree programmes, course-wise, the whole FYUGP is divided into two parts — (i) Core Courses and (ii) Common Courses. The minimum credit allocation for a 3-year programme is 84 credits in Core Courses and 36 credits in Common Courses, which comes to a total of minimum 120 credits for a 3-year programme. With the fourth year, the minimum credit requirements becomes 160. A student can however earn up to a maximum of 132 credits in a 3-year programme and 176 by the fourth year.

Multiple exits & entries:

As mentioned before, a student can exit after any year during the FYUGP. Depending on the exit level, a student can get a certificate, diploma, or a degree.

If a student exits after one year into the programme, s/he will be eligible to get a certificate, if she clears all the courses at that point of time. Similarly, s/he will be getting a diploma if he/she exist after two years into the programme, after clearing all the courses up to that point of time. Eventually, after three years, she/he will get a Bachelor's Degree.

It should however be noted that if a student exits the FYUGP at the third year with a Bachelor's Degree, s/he will not be able to seek a reentry afterwards into the fourth year. Rather s/he will need to take admission into the first year of a Master's programme.

Every student who is in the third year of the FYUGP, can advance to the fourth year. After successful completion of the fourth year, s/he gets either a Bachelor's Degree (Honours) or a Bachelor's Degree (Honours) with Research.

Exit Courses:

Every students who wants to exit before 3 years into the programme, MUST complete an additional Vocational Course of 4 credits.

Core courses:

The Core Courses determine the ultimate degree, diploma, or certificate a student will earn at the end of third (or fourth) year, second year, or first year, respectively. The performance in the Core Courses will also determine the grade of the student in the final examinations. Total minimum credit requirement is 84 for the Core Courses, which translates to 21 courses (i.e. papers) with a credit allocation of 4 per course (paper). A student will need to study at least three Core subjects. The Core Courses have to be chosen among a plethora of subjects offered (see the section on Subject Details) for both the types of degrees, respectively. In case of a Bachelor's Degree in a Stream, the components of the Core Courses are Major and / or Minors, while in case of a Bachelor's Degree in a Discipline, there are no Majors and Minors.

Major and Minors:

In case of a Bachelor's Degree in a Stream, a student either chooses a Major and Minors or just Minors from among the subjects. In any case, a student needs to complete 21 courses or 84 credits by the third year. Please see the examples that we have given in this booklet. A Major course **MUST** carry a minimum credit of 60 and a Minor course should carry a minimum credit of 12.

Usually, for majority of the students, the Core Course will consist of one Major and two Minors. But if a student desires, using the free credits (as described earlier), s/he can easily complete a third Minor as well.

Common courses:

The common courses are to be studied by all students alike and all-together they carry a total credits of 36 over a 3-year period. These courses are further divided into five (5) subcategories, as described below.

Multi-disciplinary Courses:

These are 3-credit courses spanning over five different groups of subjects—(i) Natural and Physics Science, (ii) Mathematics, Statistics, and Computer Applications, (iii) Library, Information, and Media Sciences, (iv) Commerce and Management, and (v) Humanities and Social Sciences. The level of these courses are of Class XII. Each student need to take at any three papers, each with 3-credits from these five sub-groups during Semesters 1-3.

Key Points:

A student CANNOT choose a multidisciplinary subject, if s/he has already studied that subject during Class XI-XII. Also the subject of these courses MUST not be among the Core Subjects the student has already chosen.

Ability Enhancement Courses (AEC):

This is an 8-credit course covering Modern Indian Languages (MIL) and English Usage (Communication).

Each student needs to complete two papers of 4-credits each – one from English Usage and other from the group of MIL, especially designed for this purpose. These courses have to be taken during Semesters 1-2.

Skill Enhancement Courses (SEC) These are various skill courses with total credit allocation of 9. In our structure, we have four skill courses out of which a student needs to study the first skill course of 3 credits in the second Semester. The rest three skill papers, each having 2 credits need to be studied during Semesters 4-6.

Value Added Courses (VAC):

The VAC courses will come from four sub groups—(i) Understanding India, (ii) Environmental Science, (iii) Digital and Technological Solutions, and (iv) Health & Wellness, Yoga Education, Sports, and Fitness. All together they will have a credit allocation of 6. Each student will have to take any two papers, each of 3-credits, from any three groups during Semesters 1 & 3. Here one paper from the Environmental Science group is compulsory except if the student takes a core course on Environmental Science.

Internship:

All student are to carry out an Internship with a credit allocation of 4. The internship can be carried out in any semester during Semesters 3-6. As internships are meant to be done during semester breaks, they will not interfere with other classes.

The fourth year:

In the FYUGP, the fourth year is at par with the first year of a Master's programme, as a student can directly take admission into the second year of a Master's programme after the successful completion of the FYUGP.

In the fourth year, a student has to complete one compulsory paper on Research Methodology (REM) in the Semester VII, which is a 4-credit theory paper. The rest of courses will consist of Advanced Core Courses and a Dissertation. The detailed structure for the fourth year will be published soon.

Details of Curriculum

Degree in a Stream

The complete curricula for GU-FYUGP are as follows.

Degree with Major and Minors

		Core Courses						Common Courses				
Credits	Semesters	Major	Minor #1	Minor #2	Optional Core							
22	Year 1	I	Sub-1 4	Sub-2 4	Sub-3 4			VAC-1 2	SEC-2 3	Multi-1 3	AEC-1 2	
22		II	Sub-1 4	Sub-2 4	Sub-3 4			VAC-2 2	SEC-1 3	Multi-2 3	AEC-2 2	
22	Year 2	III	Sub-1 4	Sub-2 4	Sub-3 4			SEC-3 3	Multi-1 3	INT-1 4		
22		IV	Sub-1 4	Sub-1 4	Sub-1 4	Sub-1 4	Optional 1/2/3 4	VAC-2 2				
22	Year 3	V	Sub-1 4	Sub-1 4	Sub-1 4	Sub-1 4	Optional 1/2/3 4	AEC-1 2				
22		VI	Sub-1 4	Sub-1 4	Sub-1 4	Sub-1 4	Optional 1/2/3 4	AEC-2 2				
44	Year 4	VII	Advanced Core (6 Courses) & Dissertation (16 Credits) Degree (Honours) with Research			OR	Advanced Core (10 Courses) Degree (Honours) with Research		REM 4			
		VIII										

Core Courses options — Option for a Major and two Minors.

Legends

VAC – Value Added Course
 SEC – Skill Enhancement Course
 Multi – Multidisciplinary Course

AEC – Ability Enhancement Course
 INT – Internship
 REM – Research Methodology

Core Course description:

In this case, a student takes a Major subject with minimum 15 courses and two Minor subjects with a minimum of 3 courses each over a period of three years. Apart from these, the student also needs to take 3 Core courses during Semesters 4-6 where s/he can pick any of the three core subjects s/he has already studied.

Degree with only Minors

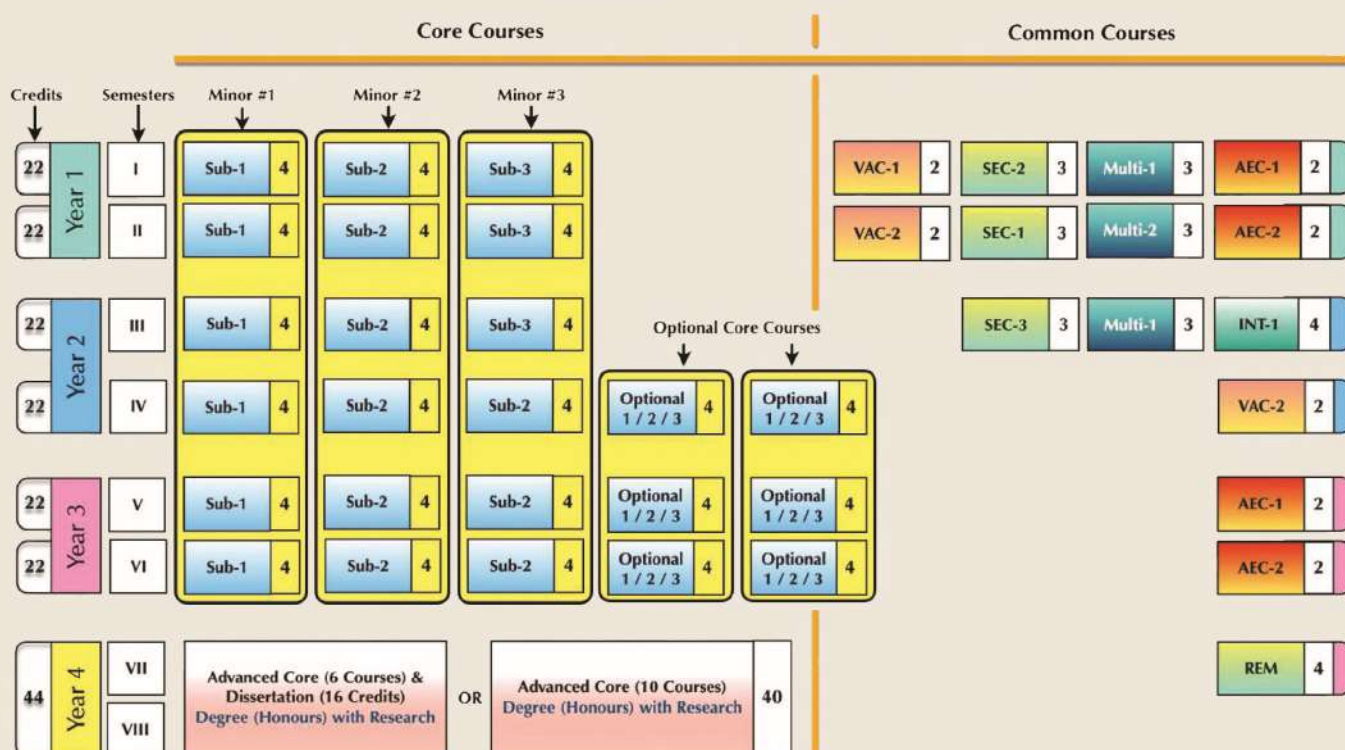

Core Course description

In this case, a student takes a three Minor subjects each with a minimum 6 courses over a period of three years. Apart from these, the student also needs to take 6 Core courses during Semesters 4-6 where s/he can pick any of the three core subjects s/he has already studied.

EXAMPLES OF CREDIT WISE DISTRIBUTION

In this examples, we are providing two options a student can have. All the examples given below are for a 3-year degree programme. The fourth year can simply be added to the examples.

Degree with Major and Minors

In this example, we show the subject distribution for a Bachelor Degree in Arts with Major and two Minors. As one can see, there are 12 Open Core Credits to be earned by a student above the minimum requirement of 120 credits. These open core can be utilised for any of the following:

- For another Minor
- For one of the Minor so that it can be converted to a Double Major
- To complete course from the fourth year

In the figure below , the distribution is shown visually. The papers marked in boldred denote that they are compulsory. One should note that the Internship can be done in any semester within the 3rd and the 6th. As an internship is always done during a break, it essentially does not interfere with the semester classes.

Semester	Core #1	Courses	Credits	Core #2	Courses	Credits	Core #2	Courses	Credits	Open Core Credits	Common Credits	Total Credits
I	History	1	4	Pol Sc	1	4	Economics	1	4		10	22
II	History	1	4	Pol Sc	1	4	Economics	1	4		10	22
III	History	1	4	Pol Sc	1	4	Economics	1	4		10	22
IV	History	1+3	16							4	2	22
V	History	1+3	16							4	2	22
VI	History	1+3	16							4	2	22
	History	15	60	Pol Sc	3	12	Economics	3	12	12	36	132
	Major			Minor #1			Minor #2					

Degree with only Minor

In this example (Fig.4.2), we show the subject distribution for a Bachelor Degree in Arts without Major. The OPen Core Credits can be utilised as described in case of above Fig..

Semester	Core #1	Courses	Credits	Core #2	Courses	Credits	Core #2	Courses	Credits	Open Core Credits	Common Credits	Total Credits
I	History	1	4	Pol Sc	1	4	Economics	1	4		10	22
II	History	1	4	Pol Sc	1	4	Economics	1	4		10	22
III	History	1	4	Pol Sc	1	4	Economics	1	4		10	22
IV	History	1+1	8	Pol Sc	1	4	Economics	1	4	4	2	22
V	History	1+1	8	Pol Sc	1	4	Economics	1	4	4	2	22
VI	History	1+1	8	Pol Sc	1	4	Economics	1	4	4	2	22
	History	9	36	Pol Sc	6	24	Economics	6	24	12	36	132
	Minor #1			Minor #2			Minor #3					

SUBJECT DETAILS – CORE SUBJECTS

In this Chapter, we describe all the existing subject details, their dependencies, and prerequisites. All the subjects are broadly divided into four streams. They are:

1. Arts
2. Science
3. Commerce & Management
4. Interdisciplinary

All these streams have their own subject groups. For example, Physical Science is a subjectgroup of Science stream. Or, Other Language is a subject group of Arts stream. These groups with their parent streams are shown below.

GU-FYUGP Structure

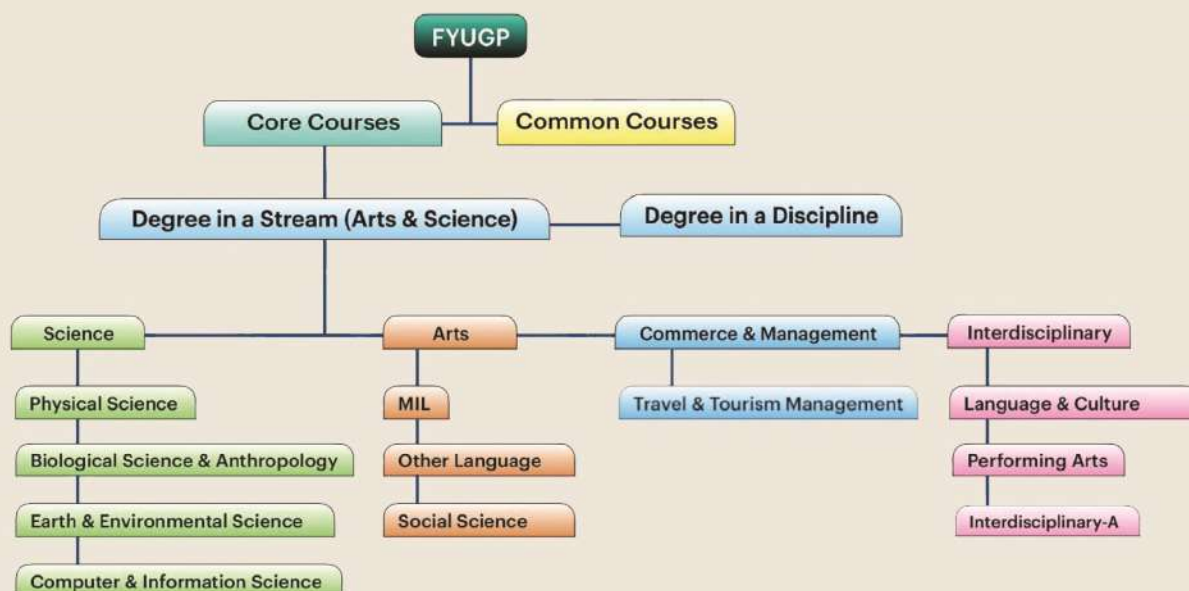

All the subject groups will have a bunch of individual subjects belonging to the respective groups, which will be described in the next section. The following applies to all these groups except the group for Commerce & Management, which will be described separately.

- All groups have their own conditions and prerequisites.
- A student can combine any three subjects from these groups subject to the fulfilment of the requirements and prerequisites.

Gauhati University will release a digital utility in due course of time through which a student will be able to see what subjects can be studied under the FYUGP in GU (based on their Class XII-level subjects and preferences).

SUBJECT GROUPS

The three streams (as shown in the previous page) — (a) Arts, (b) Science, and (c) Interdisciplinary—has their own subject groups. Each of these groups has their own constraints as to up to how many number of subjects from each subject-group can be chosen by a student. This is indicated in the previous figure with the word Max.

Key points:

A student can choose any three subjects from the subject groups Arts, Science, and Interdisciplinary.

However, the ability to take a subject from a particular group will depend on prerequisites (qualifications that a student must have, see the subsection below on Prerequisites & Requirements) and Group Constraints (see below).

All subjects have at least one paper compulsory in all semesters.

PREREQUISITES, REQUIREMENTS, & CONSTRAINTS

The prerequisites are subjects that a student must have studied (and passed) in an earlier level of education (usually Class XI & XII) in order to be able to choose a subject. Essentially, all the levels of a subject have their prerequisites, which are spelled out very visibly in the cover page of a course syllabus.

In contrast to the prerequisites, requirements are certain conditions attached to some coresubjects. For example, if a student wants to study Botany as a core subject, Chemistry as another core subjects has to be chosen. This is a 'requirement'. However, if one chooses Chemistry, there is no requirements.

Constraints refer to the maximum number of subjects a student can choose from a particular subject-group. For example, one can choose a maximum of any two subjects from the group – Biological Science & Anthropology. This is a 'constraints' for this group. Please read further to know the stream-wise subjects with group-constraints.

SUBJECT GROUPS

ARTS

- This stream has three Subject Groups – (1) MIL (Modern Indian Languages), (2) Other Language, and (3) Social Science.
- The maximum number of subjects which can be chosen from each group
- All together this stream has 17 (seventeen) subjects.

Arts			Interdisciplinary		
MIL	Other Language	Social Sciences	Language & Culture	Performing Arts	Interdisciplinary-A
Assamese	Arabic	Economics [†]	Folklore	Sattriya Tradition	Journalism & Mass Communication
Bengali	English	Education	Linguistics		Library & Information Science
Bodo	Persian	History			Community Science (Home Science)
Hindi		Philosophy			Human Rights Education
Manipuri		Political Science			
Nepali		Psychology			
Sanskrit		Sociology			
Commerce & Management					
			Travel & Tourism Management		
Max 1	Max 1	Max 3	Max 1	Max 1	Max 1

[†] Dual-Stream subjects

Note:

The subjects shown yellow colour MAY NOT have a Major option, at present. Please check with your college to know if a Major in these subjects are allowed.

INTERDISCIPLINARY

- This stream has three Subject Groups – (1) Language & Culture, (2) Performing Arts, and (3) Interdisciplinary-A (Group A).
- The maximum number of subjects which can be chosen from each group is shown in the Fig.5.3.
- All together this stream has 5 (five) subjects.
- None of the subjects in this stream has Major option.

LIST OF PREREQUISITES & REQUIREMENTS GROUPS

ARTS

Following are the prerequisites for all subjects (39 of them) of Arts, Science, Interdisciplinary streams and one subject under Commerce & Management at the entry level of the FYUGP i.e. at the first semester.

Stream : Arts		
MIL		
Subject	Prerequisites	Requirements
Assamese	Assamese (X-level) for Minor & (XII-level) for Major	None
Bengali	Assamese / Bengali (X-level)	
Bodo	Bodo (XII-level)	
Hindi	Hindi (X-level)	
Manipuri	Manipuri (XII-level) for Major & (X-Level) for Minor	
Nepali	None	
Sanskrit	Sanskrit (X-level)	

Stream : Arts		
Other Language		
Subject	Prerequisites	Requirements
Arabic	None	None
English	English (X-Level)	
Persian	None	

Stream : Arts		
Social Science		
Subject	Prerequisites	Requirements
Economics	None	None
Education		
History		
Philosophy		
Political Science		
Psychology		
Sociology		

Computation of SGPA and CGPA

$$SGPA(S_i) = \frac{\sum(C_i \times G_i)}{\sum C_i}$$

Where C_i = Number of Credits of the i th course

G_i = Grade point scored by the student in the i th course

CGPA

$$CGPA = \frac{\sum(C_i \times S_i)}{\sum C_i}$$

S_i = SGPA of the i th semester

C_i = Total number of credits in that semester

ATTENDANCE REQUIREMENT

Attendance of Students:

Students must have 75% attendance. The attendance of all courses including the Skill Enhancement courses shall be counted, and accounted for in full while determining if the student has met the minimum attendance norms of Gauhati University. In case, a student fails to have at least 75% attendance, he/she will not be allowed to sit for semester end examination and will be needed to repeat the concerned semester after the successful completion of the subsequent semesters for earning the deficit credits. Any student securing less than 75% attendance due to medical reasons will have to apply for medical leave in a prescribed form (within seven days from the date of absence) along with relevant documents/certificates etc from an authorized medical practitioner. However, after accounting for medical leave granted, the minimum attendance will still have to be 75%. If it still remains below 75%, the student will not be allowed to sit in semester end examination. Such consideration will be subject to the condition that the student must have at least 60% attendance. For absence due to participation in prescribed co-curricular activities (eg. NCC/NSS/Youth Festival/Sports etc.), the claim for CCA leave will have to be made in prescribed form and supported by authenticated certificate(s) from concerned authorities. However, the minimum attendance after accounting for CCA leave granted will still have to be 75%.

Internal Assessment (IA) :

Internal Assessment will ideally account for 20% of the total marks allotted in a course/paper. Sessional or mid-term examination will be conducted for 50% of the total marks allotted for IA of a course/paper. 20% of marks allotted for IA will be awarded to the students based on class attendance as follows:

- (i) From 76% to 86% attendance: 1 mark
- (ii) From 81% to 85% attendance: 2 marks
- (iii) From 86% to 90% attendance: 3 marks
- (iv) From 91% and above: 4 marks

Remaining 30% of the marks allotted for IA will be distributed and awarded on the basis of performance of the students on the following criteria:

- (i) Home assignment
- (ii) Seminar/Group discussions
- (iii) Field work
- (iv) Performance in co-curricular and extra-curricular activities

“Subject combinations” and “Elective Papers” will be offered as per Gauhati University directions and guidelines.

Study Centre of Krishna Kanta Handiqui State Open University (KKHSOU)

Mayang Anchalik College has recognized Study Centre of Krishna Kanta Handiqui State Open University(KKHSOU) since July, 2023. The Study Centre is offering M.A. Courses in Assamese, Economics, English, Education and Political Science apart from B.A. (Major/ Minor) Courses. Dr Ranjan Timsina is rendering service as the Co-ordinator of the Study Centre. (Mobile No: 9613141530)

STUDY CENTRE OF IDOL

Mayang Anchalik College has introduced a study centre of IDOL to carry our various Distance Learning Course from academic session 2019-20. Dr. Guneswar Deka, Head of the Department of Political Science is appointed as coordinator of IDOL study centre for smooth functioning of the centre.

MOOC (MASSIVE OPEN ONLINE COURSE)

Mayang Anchalik College is also advised to student for joining the MOOC course (Massive Open Online Course) under Swayam Platform from this academic session. The Co-ordinator of MOOC courses is look after for smooth functioning of the course in our College.

SKILL DEVELOPMENT COURSE

Mayang Anchalik College has also signed 32 numbers of MOU with different organizations to carry out a number of Skill Development course from academic session 2019-20. **Dr. Utpal Nath**, Assistant Professor of Economics, is appointed as Co-ordinator for smooth functioning of the skill development course in our College.

RESERVATION OF SEATS:

In accordance with the Government Policy, there is a provision for reservation of seats for candidates belonging to OBC, MOBC, SC, ST (Plain), and ST (Hills). Some seats are also reserved for Differently abled, NCC, Scout and Guide and the candidates excelling in Co-Curricular activities.

COLLEGE UNIFORM:

Mayang Anchalik College has introduced its dress code by way of College Uniform. The particulars of College Uniforms are as follows:

For Boys : White Shirts and Black Formal Pants

For Girls : Black Salwar, White Kamiz and Black Dupatta

Both boys and girls shall wear Black Blazer or Cardigan in winter. Jacket, Jeans and T- Shirts are not a part of the dress code.

A College "Logo", which shall be supplied by the College authority at the time of admission, has to be affixed by each and every student on their uniforms. While the boys shall affix the College logo on the shirt pocket position, the girls on the Kamiz on the right arm position.

It is mandatory for the students to wear the College Uniforms while coming to College for attending classes and appearing in the examinations. No student shall be allowed to attend classes, festivals, or any other functions without proper Uniform. They must always use clean and properly ironed dresses.

STUDENTS' CODE OF CONDUCT:

Attendance:

Regular attendance in all the classes is mandatory for the Students. Students having a minimum of 75% are declared as regular and are allowed to appear University exam. If a student has an attendance percentage below 75%, he/she shall be treated as Non-Collegiate. Moreover, a student failing to attend 60% of the total classes would be declared as Dis-Collegiate. If a student fails to attend classes for 25 days at a stretch from the date of commencement of classes, he/she will forfeit his/her seat.

Discipline Among Students:

Students are expected to maintain a high standard of discipline in the College Campus. The College Authority lays down certain rules and regulations, violation of which may make a student liable for disciplinary action. Any willful damage of College property would be treated as a serious offence and stern action will be taken in this regard.

College Uniform:

Wearing of prescribed uniform in the College Campus is mandatory for each and every student. A student breaking the uniform code would not be allowed to enter the College Premises. It is also compulsory for each and every student to wear uniform during examinations.

College Identity Card:

Each and every student of the College is issued a non-transferable identity card and it is expected that she/he carries it at all times inside the College Premises. In case the card is lost or damaged, concerned authority must be informed immediately.

College Notice Board:

Students are expected to grow the habit of reading the College Notice Boards regularly. Any notice that has to be circulated in the College through the Notice Boards must be approved by the College Authority.

Ragging:

Ragging in any form inside the College and Hostel Premises is strictly prohibited. Students indulging in ragging will be subjected to strong disciplinary action as per the directives of the Supreme Court/ High Court.

Campus Cleanliness:

It is considered to be the duty of each and every student to keep the College Campus clean at all costs. Spitting, writing, and sticking anything on the walls in the College Campus will be treated as a punishable offence.

Energy Conservation:

In order to conserve energy, each and every student is expected to grow and practice the habit of switching off fans and lights when not in use.

Use of Mobile Phones:

Use of mobile phone in the College Campus is strictly prohibited. Students violating this rule would invite disciplinary action from the concerned authority.

Tobacco Chewing:

Smoking or chewing of tobacco and paan in any form is strictly prohibited inside the Campus.

Silent Zone:

During teaching hours all areas around Classrooms shall be treated as silent zones. The authority can take action against students who create disturbance during College teaching hours.

Use of Library:

Students are expected to maintain discipline in the Library and be careful in handling.

Parking Facility:

It is compulsory for all students with two Wheelers to submit the copies of their Driving License and Registration Card to the College authority failing which they will not be permitted to avail the parking facility outside the College Premises.

Besides, students must follow the following rules:

- Exhibition or introduction of any Political Party emblem/poster at the College Premises is forbidden. Disciplinary action will be taken against a student resorting to such acts.
- Students shall desist from resorting to acts calculated to cause public nuisance, disturbance of public peace, law and order. They shall maintain perfect silence inside the Campus and desist from disorderly behavior.
- Unbecoming/abusive/defamatory/derogatory language or ungentlemanly conduct shall be severely dealt with.
- Students shall take proper care of the College Property, Furniture, and Premises.
- No society can be formed in the College nor shall any person be invited to address a meeting at the College Premises without the permission of the Principal.
- Communal harmony must be maintained.

ANY OF THE FOLLOWING ACTS BY A STUDENT SHALL BE CONSIDERED A MAJOR BREACH OF DISCIPLINE:

- All acts of violence and forms of coercion such as gheraos, dharnas, sit-ins which disrupt the normal academic and administrative functioning of the College.
- Misbehavior with teaching and non-teaching staff of the College in and outside the College Campus.
- Habitual unpunctuality.
- Furnishing false Certificates or false information.
- Any form of immoral act.
- Sexual harassment.
- Use of intoxicants, drugs, etc. at the College Premises.
- Eve-teasing or disrespectful behavior with a girl student.
- Arousing communal, caste or regional feeling among students.
- Ragging in any form.
- Audio and Video recording of any kind inside the College Campus.
- Any other act which may be considered by the Principal as an act of violation of discipline or misconduct.

RAGGING:

Ragging in any form is strictly prohibited within or outside the College Campus. Ragging ordinarily means any act, conduct, or practice by which dominant power or status of senior students is brought to bear on junior students who are freshly enrolled. An Anti-ragging Committee as per the UGC Guidelines has already been constituted in the College. Anti-Ragging Squads and an Anti-Ragging Committee are empowered to take sue moto action upon receiving a complaint. Ragging includes an individual or collective acts or practices which:

- a. Involve physical assault or threat or use of physical force.
- b. Violate the status, dignity and honour of women student.
- c. Expose students to ridicule and contempt and affect their self-respect.
- d. Entail verbal abuse and aggression, indecent gestures and obscene behavior.

An individual or a collective act or practice of ragging and indiscipline shall be viewed seriously and dealt with swiftly and severely.

ANTI-SEXUAL HARASSMENT:

Mayang Anchalik College has evolved a policy against sexual harassment to create for women students on its Campus a gender-just and secure environment. The College will have a Complaints Committee to take care of the complaints of women students in this regard. The complaints will be kept confidential and the Committee will have the power to recommend severe action(s) against the perpetrators.

MONITORING ACADEMIC PROGRESS:

The Principal and the teachers of the College will meet the students and guardians on convenient dates during the academic session to make first hand assessment of academic progress, or any problems related to teaching and learning.

GUARDIANS MEET:

There will be occasional meeting of the parents and guardians with the Principal and teachers. Guardians should attend such meetings to express their opinions on academic and other developmental matters of their wards.

STUDENT FACILITIES & FEATURES

Dipan Chandra Nath Central Library:

The "Dipan Chandra Nath Central Library" named after late Dipan Chandra Nath, the founder Secretary of the Managing Committee of the College is centrally located and easily accessible. The library has a holding of over 14,000 books of both textbooks and references and has subscribed to many journals and newspapers.

Membership of the Library is open to the students, teachers and non-teaching staff of the College. Books can be borrowed by all the members of the Library.

The Library is kept open from 9.30 am to 4.30 pm throughout the year on all working days.

Departmental Library:

Apart from the Central Library, each department has its own Library with a number of books both texts and references for the benefit of students and faculties.

Teaching and Learning Facilities:

The teaching-learning process is interactive and participatory. Students are encouraged to take active part in the process. Academic instruction comprises of Classroom Lectures, Tutorials, Discussions, Seminars, Assignments, Library Works, Field Works, Projects and Presentations by the students. Each Department has Audio-Visual Class Room to enhance the quality of teaching-learning process.

Identity Card:

A non-transferable Identity Card will be issued to every student at the time of admission. The Identity Card containing relevant information of the student along with a recent stamp size photograph will be duly endorsed by the Principal. The Identity Card will be issued annually and the old one must be surrendered at the end of the academic session for renewal. Students are to possess their Identity Cards with them at all times, and must produce the same on demand.

Students Welfare Fund:

The College has constituted a Students Welfare and CSC Cooperative Society Ltd. The objective of the fund is to render financial assistance to the meritorious students having poor financial background.

The College Magazine/Wall Magazine:

The College magazine entitled 'Pragati' is published annually. The magazine publishes articles by teachers, students and office staff and reviews of educational, cultural, social, and sports activities of the College. The magazine is edited by a student editor under the supervision of a member of the teaching staff. Besides, an number of Wall Magazines are issued by various departments to inculcate the habit of writing of the students.



National Services Scheme (NSS):

The National Services Scheme unit of the College is actively engaged in various community welfare services. Students desirous of joining the NSS can contact the concerned Programme Officer after the commencement of the academic session.

Boys' and Girls' Common Rooms:

Common Rooms for both boys and girls are well furnished.

Games and Sports:

All Kinds of games and sports facilities are available in the College. The College has its own playground. The construction of an Indoor Stadium has been completed recently.



Alumni Association:

The College has a Registered Alumni Association. The Association has always responded whenever called upon to do their bit for the welfare of the College.

College Notice Board:

Notice, instructions, and information of all kinds for students are put up on the Notice Board. Students are advised to have a look at the Notice Board regularly.

Remedial/ Tutorial Classes:

Remedial/ tutorial classes are provided to (slow learner) those who require extra guidance and help with certain subjects. Students belonging to SC/ST and other minority sections are encouraged to take the classes.

Information & Career Guidance Cell:

There is a full-fledged Information & Career Guidance Cell in the College. The faculty-in-charge of the Cell arranges talks with career counselling experts so that the students can benefit from such interactions. Through such counselling, the students get relevant and necessary information about career prospects.

Photocopy Facility:

The College provides photocopying facility within the Premises of the cash counter office. Students can avail internet facility on request while the computers are free.

Boys Hostel:

Construction of a hostel for boys with unlimited seat capacity is underway. It is expected to be completed by the end of the current academic session. Subject to availability of seats, outstation students will be allotted rooms in the hostel on a sharing basis. The College does not promise accommodation to every student and those who are allotted rooms shall submit to hostel rules.

Women's Hostel:

Mayang Anchalik College has a Girls' Hostel with limited seat capacity. Subject to availability of seats, outstation students will be allotted rooms in the hostel on a sharing basis. The College does not promise accommodation to every student and those who are allotted rooms shall submit to hostel rules.

Indoor Stadium:

Construction of an Indoor Stadium of the College has already been completed with the financial assistance from the UGC. The facilities to be provided in the Indoor Stadium include Chess, Carom, Table Tennis, Badminton, etc. for nurturing the hidden talents of the students.

College Canteen:

The College has made arrangements for canteen inside the campus both for the teachers and the students. The canteen remains open from 8.30 am to 5 pm, except Sundays and holidays.

Scholarship and incentives:

Students of the College can avail this following scholarships and incentives on fulfilling the eligibility norms.

- National Scholarship.
- State Merit Scholarship.
- Post metric scholarship (For students belonging to ST, SC, OBC, and MOBC category)
- Scholarship for minority students.
- Ishan Uday of UGC.

Dipan Chandra Nath Memorial Award:

Late Dipan Chandra Nath Memorial Awards sponsored by the family of the founder secretary of Mayang Anchalik College, GB and awarded to the students securing highest mark among the first class holders from all the departments of the College.

Best Graduate Award:

Best graduate award, sponsored by the Mayang Anchalik College GB is awarded to the students securing highest marks among all first class holders from all the department of the College.

Ramp for the Differently Abled Persons:

The College has constructed a ramp for the differently abled persons to minimize the challenges they face in pursuing their College education.

Grievance Redressal Cell:

This cell is for the benefit of the students, teachers and employees of the Colleges to voice their grievances without hesitation regarding College activity directly to the Principal. The students also enjoy the benefits of assessing the teaching learning procedures through the mechanism of students' feedback.

Students gymnasium (Vyamagar):

The College has a newly established well equipped gymnasium with state of the art facilities that can be used by the students and teachers of the College for nurturing their health.

Travel concession:

It can be availed by the students during vacations or during academic tours conducted by the College with financial assistance from Government.

International Inspiration Economy Book Club:

The College has a centre of International Inspiration Economy Book Club, Bahrain which was setup with a view to make the students aware of new concepts of economy like Inspiration Economy, Resilience Economy and Youth Economy.

Car Pool:

Mayang Anchalik College always encourage its staff to follow Car Pool system to reduce Carbon Emission for a clean environment.

Insurance Scheme :

This facility is provided to the students of the College by the authority with consultation with State Bank of India, Rajamayang Branch.

Seminar and Workshops:

Seminar and Workshops are organized in a regular basis for the benefit of students and teachers to improve the students along with teachers' communicative skills as well as to impart knowledge in different areas.

Annual College Week:

In order to encourage all round development of the students, the annual College Week is organized every year with the active initiation of the students union. Students are encouraged to participate in sports and other co-curricular activities during this event.

ORGANISATIONS INSIDE THE CAMPUS:

College Students' Union:

The College Students' Union is formed every year after the General Election in which the students are given the responsibility for selecting their representatives. The Union looks after the needs of the students. It also acts as a mediator between the students and the Principal in matters concerning the students' community.

College Teachers' Unit:

The College Teachers' Unit looks after needs and requirements of the teachers. The Unit concerns itself with different academic activities and discussions.

College Employees' Unit:

The College Employees' Unit is formed to look after the needs of the College employees.

Forum for Economic and Social Change:

The Forum for Economic and Social Changes is one of the initiatives of the Department of Economics. It studies the economic potential of natural and human resources with cause and effects and analyses their impact on social changes. It needs to be mentioned here that, to carry out social responsibility, the College has adopted the village Burhamayang to contribute to its social, economic, academic, and cultural advancement.

Research and Publication Unit:

The College has a research and publication cell. It is entrusted with the responsibility of publication of the College Magazine, Seminar Proceedings, College Prospectus and Application Forms, etc. The Unit has mooted a plan to stock all the research works such as M.Phil. and Ph.D. theses, and MRP works carried out by the faculty members across departments of the College.

Tourist Information Centre

Department of Economics, Mayang Anchalik College renders ready information about the Mayang Area and Pobitora Wildlife Sanctuary for interested persons on contact.

Literary Forum:

Department of Assamese, Mayang Anchalik College runs a literary forum which publishes an annual Magazine on literature.

College Museum:

The College has taken an initiative to establish a well maintained, rich College Museum. It aims at preserving the historical cultural and archeological heritages of greater Mayang, the land famous for the practices of black magic, since time immemorial. It attempts to illuminate the students regarding the socio-cultural background and history, glory and civilization of the locality. The students are also encouraged to collect and contribute various items to the Museum.

VIBGYOR:

VIBGYOR is a joint initiatives of the department of MIL and department of Education. It undertakes different activities for upliftment of the students and society in the field of culture, education and literature (VIBGYOR indicates the seven colours of the rainbow).

Helping hand:

It is an unit for social work, for helping poor students and villagers, conducted by the Department of Political Science, Education and History togetherly.

Branch of Youth Red Cross Unit:

The College has initiated a branch of Youth Red Cross Unit recently. It will undertake different activities to uplift the locality function different angles.

EXAMINATION AND EVALUATION:

One Sessional Examination is conducted in the month of April for 2nd, 4th and 6th semester and in October for 1st, 3rd and 5th semester.

For continuous evaluation of the performance of the students, the college conducts Unit Tests and Sessional Examinations.

MEMBERS OF THE TEACHING AND THE NON-TEACHING STAFF

PRINCIPAL:

Dr. Ranjit Kumar Kalita, M.Sc., Ph.D.

ACADEMIC IN-CHARGE:

Dr Guneswar Deka, M.A., Ph.D. (GU)

FACULTIES:

DEPARTMENT OF POLITICAL SCIENCE:

Dr Guneswar Deka (HoD), M.A., Ph. D. (GU)

Mr Paban Kumar Bishaya, M.A., M. Phil.

Rafiqueel Islam, M.A., M. Phil.

Mr Bijay Medhi, M.A., M. Phil.

DEPARTMENT OF EDUCATION:

Reza Shadullah Ahmed, (HoD) M.A., M. Phil.

Ms Kabita Medhi, M.A., M. Phil.

Ms. Moni Biswas, M.A, B.Ed. (Temporary)

DEPARTMENT OF ASSAMESE:

Dr Minakshi Tamuli, M.A., Ph.D. (GU), (NET, SLET)

Mr Atul Ch. Nath, M.A., M. Phil.

Ms Charu Prava Chaliha, M.A., M. Phil.

Mr Abhiram Sarkar, M.A., (SLET)

Dr Bristi Kalita, (HoD) M.A., PG Diploma in Oriya (NET, SLET), Ph. D.

DEPARTMENT OF ECONOMICS:

Mr Robin Kumar Kalita, (HoD) M.A., M. Phil.

Ms Leena Kumari Borah, M.A., M. Phil.

Dr Utpal Nath, M.A., M. Phil., Ph. D. (GU)

Mr Tilak Nath, M.A., M. Phil.

DEPARTMENT OF HISTORY:

Mr Dhanya Ram Roy, (HoD) M.A., M. Phil.

Mr Sarat Chandra Sarma, M.A., B. Ed., M. Phil.

Dr Utpal Saikia, M.A., LLB, PGDHRM, (SLET), Ph. D. (GU)

Mr. Angshuman Borah, NET (Undergoing Ph.D. in GU)

DEPARTMENT OF ENGLISH:

Dr Ranjan Timsina, (HoD) M.A., M. Phil., Ph.D.

Mr Samir Nath, M.A., M. Phil.

DEPARTMENT OF TTM:

Mrs. Parul Das

DEPARTMENT OF FPQM:

Miss Kalyani Sarma

OFFICE STAFF:

Sri Dilip Saikia, B.A., Senior Assistant

Sri Chittaranjan Nath, B.A., Senior Assistant

Sri Kandarpa Saikia, M.A., Junior Assistant

Sri Bipul Deka, B.A., Junior Assistant

Ms Samsun Nehar Begum, Junior Assistant

Sri Manjit Deka, Junior Assistant

LIBRARY STAFF:

Sri Chandra Kanta Borah, Librarian, MLI Sc, M. Phil.

Sri Utpal Nath, Assistant Librarian, B.A., BLI Sc.

Sri Ananta Kumar Borah, B.A., Library Assistant

Sri Khargeswar Borah, B.A., Library Bearer

GRADE IV EMPLOYEES:

Sri Mihir Nath

Sri Tulen Nath

Sri Biren Nath

Sri Manoj Deka

Mrs Pramila Devi

VARIOUS WINGS OF THE COLLEGE

INTERNAL QUALITY ASSURANCE CELL (IQAC):

For performance evaluation, assessment and accreditation and quality upgradation, the College has formed/established an Internal Quality Assurance Cell (IQAC). The basic purposes of the IQAC are:

- * To ensure continuous improvement in the entire operations of the Institution.
- * To assure stakeholders connection with the Institution and
- * To develop a system for conscious, Consistent and Catalytic improvement in the performance of the institution

A facilitating and monitoring body to advise on the rates and functions of the IQAC, has been formed in the college with the following Composition:

Chairperson	:	Dr Ranjit Kumar Kalita
Co-ordinator	:	Mr. Robin Kumar Kalita
Joint co-ordinator	:	Dr. Ranjan Timsina Dr Minakshi Tamuli Dr Utpal Saikia
Asstt. Co-ordinator	:	Dr. Utpal Nath
Senior Adm. Officer	:	BDO, Mayang Dev. Block, Morigaon
Senior Adm. Officer	:	Range Officer, Pobitora W. L. Sanctuary.

Member from management : Mr. Rabidhar Nath
Member from local Society : Mr. Prafulla Kumar Bhuyan.
Alumni Member : Mr. Bireswar Keleng

QUALITY ADVISORY COMMITTEE (PLANNING BOARD):

A facilitating and monitoring body to advise on the rates and functions of the QAC, was formed in the College with the following composition:

Advisor : President, G.B.
Chairperson : Dr. Ranjit Kumar Kalita
Member from Management : Mr. Prafulla Kr. Bhuyan
Senior College Administration: Dr. Phani Bhushan Nath
Senior administrative Officer : Range Office, Pobitora WL sanctuary.
Member from GU : Dr. Rajib Handique, Dept. of History, GU.
Member form Teacher : Dr. Minakshi Tamuli
Dr. Utpal Nath
Mr. Chandra Kanta Borah.

The following Committees /Cells have been formed by the IQAC, Mayang Anchalik College and vested with respective responsibilities for all round development of the institution:

ACADEMIC COMMITTEE:

Advisor : Dr. Ranjit Kumar Kalita
Incharge : Mr. Dhanyaram Roy
Members : Dr. Guneswar Deka
Mrs. Kabita Medhi
Dr. Minakshi Tamuli
Dr. Ranjan Timsina
Mr. Atul Ch. Nath
Mr. Robin Kumar Kalita
Mr. Samir Kr Nath
Mr. Sarat Sarma
Mrs. Leena Kumari Borah
Mrs. Charuprava Chaliha
Students Member

Function: To look after Student discipline, Annual Academic Calendar and Prospectus, Schedules for examination, Best practices of the College, Student body election and College Week and UGC related activities.

ICC COMMITTEE (Anti Sexual Harasment Cell):

Chairman : Dr. Ranjit Kumar Kalita
Coordinator : Dr. Bristi Kalita
Members : Dr. Minakshi Tamuli
Mrs. Kabita Medhi
Mrs Charu Prava Chaliha
Mrs Leena Kumari Borah
Students Member

Function: To deal with the issue of genderbased violence and to conduct gender sensitization program.

COMMITTEE OF CODE OF CONDUCT :

Advisor	:	Dr Ranjit Kumar Kalita
Coordinator	:	Mr Paban Kumar Bishaya
Members	:	Dr. Minakshi Tamuli Mrs. Kabita Medhi Mr Robin Kumar Kalita Mr. Dhanya Ram Roy Mr Samir Kumar Nath Students Member

Function: To look after the student discipline, college uniform, rules and regulation of the college.

RESEARCH AND DEVELOPMENT CELL :

Chairperson	:	Dr Ranjit Kumar Kalita
Convenor/Director	:	Dr. Guneswar Deka
In Charge of Research Program and Policy Development	:	Dr Bristi Kalita
Member	:	Dr. Minakshi Tamuli
Incharge of Collaboration and Communication	:	Dr. Ranjan Timsina
Member	:	Mr. Dhanya Ram Roy
In charge of Intellectual Property Right, Legal and Ethical Matters	:	Dr. Utpal Saikia
Member	:	Mrs. Kabita Medhi

Function:

- * To encourage the teacher and student to develop research cultural and to keep all records of reserach project
- * To arrange and conduct Seminar/Workshop/Symopsis etc.
- * To study the best practices (teaching and learning) of other college
- * To find new idea of the best practices that will be beneficial for colleges stakeholders.
- * To survey according to local community needs.
- * To publish Research Works
- * To dvelop research infrastructure in Colege Campus.

EQUAL OPPORTUNITY CELL :

Chairperson	:	Dr Ranjit Kumar Kalita
Convenor/Director	:	Mr. Atul Ch. Nath
Members	:	Mr. Robin Kumar Kalita Dr. Ranjan Timsina Mr. Sarat Ch. Sarma Dr. Utpal Saikia

EXTENSION ACTIVITY CELL:

Convenor	:	Dr. Utpal Nath
Member	:	Reza Shadullah Ahmed Mr. Robin Kumar Kalita Dr. Ranjan Timsina Mrs. Kabita Medhi Dr. Minaskhi Tamuli Dr. Bristi Kalita Mr. Chandra Kanta Borah Mr. Tilak Nath Mr. Bipul Deka Cultural Secretary, Student Union

FUNCTIONS::

- * To encourage student participation in the State/ National level sports events
- * To promote women's participation in sports
- * To provide optimum Indoor and Outdoor sport facilities
- * To arrange coaching for different games for stakeholders
- * To promote Yoga/ Gymnastic activities

PARENT-TEACHER ASSOCIATION:

Convenor	:	Mrs Kabita Medhi
Members	:	Mrs. Leena Kumari Borah Mr Paban Kumar Bishaya Mr. Robin Kr Kalita Mr. Dhanya Ram Roy Dr Utpal Nath Dr Utpal Saikia Mr Dilip Saikia

Functions:

- * To Develop teacher-student-guardian friendly and cultural relationship.
- * Involve parents/ guardians to conduct various programmes.
- * To discuss crucial matters regarding the students and activities of the college.
- * To arrange award for students for outstanding performances/activities in academic as well as co-curricular Activities in memory of local national figures.

COMMITTEE FOR GAMES AND SPORTS:

Convenor	:	Rafiqueel Islam
Members	:	Mr Paban Kumar Bishaya Mr. Dhanya Ram Roy Dr Ranjan Timsina Mr Sarat Chandra Sarma Mr Tilak Nath Mr Chitta Ranjan Nath Reza Shadullah Ahmed

FUNCTIONS:

- * To be registered under Society Registration Act
- * Other functions to be determined by the Committee itself within the area of its aims and objectives

INFORMATION AND CAREER GUIDANCE CELL:

Coordinator : Mr Samir Kumar Nath
Members : Ms Charu Prava Chaliha
Dr Utpal Nath
All Heads of the Departments
Students Member

FUNCTIONS:

- * To conduct survey among students on their careers options
- To arrange programme to create awareness about the importance of higher education
- To arrange Coaching Classes on CAT, MAT, APSC, UPSC etc.
- To conduct Orientation programmes for freshers
- To organize programmes for personality development , soft skills and communication skills
- To provide job information
- To maintain records of participation of students regarding their career.

ALUMNI ASSOCIATION:

Coordinator : Mr Atul Chandra Nath
Members : Mr Bijay Medhi
Mr Abhiram Sarkar
Dr Utpal Saikia
Mr Ananta Borah
Mr Bipul Deka
Dr Utpal Nath
Mr Bireswar Keleng
Students Member

FUNCTIONS:

- * To register under Society Registration act.
- * Other functions to be determined by the Committee itself within the area of its aims and objectives.

LIBRARY COMMITTEE

Convenor : Mr Chandra Kanta Borah
Members : Dr Guneswar Deka
Robin Kumar Kalita
Dr Ranjan Timsina
Ms Charu Prava Chaliha
Mr Atul Chandra Nath
Md. Reza Shaddullah Ahmed
Md. Rafiquel Islam
Dr Utpal Nath

FUNCTIONS:

- * To act as a channel of communication between the Library and the College Authority
- * To maintain expenditure
- * To make recommendations of Library equipments, books and journals
- * To provide/ introduce book-borrow system
- * To provide e-journals
- * To work for the strategic development of the Library
- * To introduce feedback system of the readers (especially teachers)
- * To observe College Library day
- * To Establish the Library as an information centre

CANTEEN SUPERVISORY COMMITTEE:

Advisor	:	Dr Ranjit Kumar Kalita
In-charge	:	Mrs Kabita Medhi
Members	:	Mr Tilak Nath Mr Chitta Ranjan Nath Mr Mihir Nath Mr Manoj Dekka

STUDENT GRIEVANCE REDRESSAL CELL:

Chairperson	:	Dr Ranjit Kumar Kalita
Coordinator	:	Kabita Medhi
Members	:	Mr Paban Kr. Bishaya Rofiquel Islam Dr Utpal Saikia
Student invitees	:	Gitanjali Saikia
Ombudsperson	:	Dr Phani Bhushan Nath, Ex Principal

INSTITUTION'S INNOVATION COUNCIL:

Chairperson	:	Dr Ranjit Kumar Kalita
Convenor	:	Mr Robin Kumar Kalita
Vice President	:	Dr Ranjan Timsina
Social Media Coordinator	:	Mr. Dhanya Ram Roy
Internship Activity Coordinator	:	Reza Shadullah Ahmed
IPR Activity Coordinator	:	Dr Bristi Kalita
ARIIA and NIRF Coordinator	:	Dr Utpal Nath
Innovation Activity Coordinator	:	Mr Samir Kumar Nath
Start-up Activity Coordinator	:	Dr Utpal Saikia

ADMISSION COMMITTEE:

Chairperson	:	Dr Ranjit Kumar Kalita
Convenor	:	Mr Samir Kumar Nath
Members	:	Mr Robin Kumar Kalita Dr Utpal Saikia Reza Shadullah Ahmed Mr Atul Chandra Nath Mr Paban Kumar Bishaya Mr Utpal Nath Mr Bipul Dekka

NEP TASK FORCE:

Nodal Officer : Mr Dhanya Ram Roy

ACADEMIC BANK CREDIT :

Nodal Officer : Dr Utpal Saikia

COLLEGE MUSEUM COMMITTEE :

Incharge : Dr Utpal Nath
Members : Mrs Kabita Medhi
Dr Minakshi Tamuli
Mr Chandra Kanta Borah
Mr Bipul Deka
Students Member

ANTI-RAGGING COMMITTEE:

President : Dr Ranjit Kumar Kalita
Co-ordinator : Dr Guneswar Deka
Nodal Officer : Mr Robin Kumar Kalita
Members : Mrs Kabita Medhi
Mr Dhanya Ram Roy
Mrs Charuprabha Chaliha
Mr Samir Kumar Nath
Mr Bijoy Medhi
Mr Dilip Saikia
Guardian Member, GB Member, Student Union Member

ANTI-RAGGING SQUAD:

President : Dr Ranjit Kumar Kalita
In-Charge : Mr. Paban kumar Bishaya
Members : Dr. Ranjan Timsina
Reza Shadullah Ahmed
Mrs. Leena Kumari Borah
Dr Minakshi Tamuli
Mr. Sarat Chandra Sarma
Mr. Tilak Nath
Mr. Chitta Ranjan Nath
Mr. Ananta Kr. Borah
Mr. Tulen Chandra Nath
General Secretary, Students' Union

EXAMINATION COMMITTEE:

Advisor : Dr Ranjit Kumar Kalita
Co-ordinator : Dr. Minakshi Tamuli
Members : Mrs. Kabita Medhi
Mr. Atul Ch Nath
Mr. Dilip Saikia
Mr. Chitta Ranjan Nath
Mr. Kandarpa Saikia
All the Departmental Heads.

SKILL DEVELOPMENT CELL:

In-charge : Dr. Utpal Nath
Members : Dr. Utpal Saikia
Reza Shadullah Ahmed
Md. Rafiqul Islam
Mr. Chandra Kanta Borah
Sri Manjit Deka

PROSPECTUS COMMITTEE:

Advisor : Dr Ranjit Kumar Kalita
Convenor : Dr. Ranjan Timsina
Dr. Utpal Saikia
Members : Sri Utpal Nath
Sri Manjit Deka

FEES RE-STRUCTURE COMMITTEE:

Advisor : Dr Ranjit Kumar Kalita
Convenor : Dr. Utpal Nath
Members : Mr. Robin Kumar Kalita
Mr. Chandra Kanta Borah
Mr. Abhiram Sarkar
Mr. Dilip Saikia
Sri Utpal Nath

ACADEMIC CALENDER COMMITTEE:

Convenor : Dr. Minakshi Tamuli
Member : All the Departmental Heads.

CELL FOR EXPLORING TRADITIONAL KNOWLEDGE AND PRACTICES

Convenor : Dr Utpal Nath
Member : Mr Atul Chandra Nath
Mrs. Leena Kumari Borah
Mr Chandra Kanta Borah
Mr Bipul Deka

CLASS ROUTINE COMMITTEE:

Advisor	:	Dr. Mahananda Borah
Convenor	:	Mrs. Kabita Medhi
Members	:	Mr. Paban Kr. Bishaya Dr Minakshy Tamuli Mr. Robin Kumar Kalita All the Departmental Heads.

GREEN CELL:

Co-ordinator	:	Dr. Utpal Saikia Mr. Sarat Sarmah
Members	:	Mr. Robin Kumar Kalita Mrs. Kabita Medhi Mr. Samir Kr. Nath Dr. Utpal Nath Rafiquel Islam Mr. Bijoy Medhi Mr. Abhiram Sarkar.

FUNCTIONS:

- * To Initiate plantation programmers inside and outside the College Campus.
- * For monitoring and maintaining the trees.
- * To generate awareness about conservation of nature and wildlife.

LEGAL CELL:

Advisor	:	Dr. Guneswar Deka
Co-ordinator	:	Dr. Utpal Saikia
Members	:	Reza Shadullah Ahmed Dr. Minakshi Tamuli Mr. Atul Ch. Nath Mr. Sarat Chandra Sarma Mr. Abhiram Sarkar

Functions:

- * To provide legal assistance to the student community.
- * To provide assistance to the victims of domestic violence/ child trafficking etc. within the locality of Mayang.
- * To organize legal awareness programmers.

WOMEN CELL:

Co-ordinator	:	Dr. Bristi Kalita
Members	:	Mrs. Kabita Medhi Dr. Minakshi Tamuli Mrs. Charuprava Chaliha Mrs. Leena Kumari Bora Mrs. Samsun Nehar Begum

REMEDIAL CLASS MONITORING COMMITTEE:

Co-ordinator	:	Mr. Robin Kumar Kalita
Members	:	Mr. Atul Ch. Nath Dr. Bristi Kalita Mr. Bijoy Medhi

UNNAT BHARAT ABHIYAN (UBA):

Coordinator	:	Dr Utpal Nath
Adopted Villages	:	1. Rajamayong 2. Hatimuria 3. Burhamayong 4. Chanaka 5. Kalshila

NSS (NATIONAL SERVICE SCHEME)

ADVISORY COMMITTEE:

Chairman	:	Dr Ranjit Kumar Kalita
Programme Officer	:	Dr Ranjan Timsina
Member (Staff)	:	Mr Robin Kumar Kalita Dr Utpal Saikia Mr Chitta Ranjan Nath
Member (Adopted Village)	:	Mr Madhuram Nath, Rajamayong Mr Shraban Sarmah, Rajamayong
NSS Leader (Student)	:	Rudra Baruah Sadikul Islam Pallabi Biswas
Member (Development Body):	:	Mr Rabidhar Nath, G.B. President Mr Dipak Saikia, G.P. President
Lady Member(Staff)	:	Dr Minakshi Tamuli Mrs Kabita Medhi Dr Bristi Kalita
Adopted Village	:	Rajamayong (Murabori)

YOUTH RED CROSS UNIT

Programme Officer	:	Dr Guneswar Deka Mrs Kabita Medhi Mr Atul Chandra Nath
-------------------	---	--

DIGITAL LEARNING CELL:

Coordinator	:	Mr Chandra Kanta Borah
Members	:	Dr Utpal Saikia Mr Dhanya Ram Roy

STUDENTS SERVICE CENTRE:

In- Charge	:	Dr Ranjan Timsina
------------	---	-------------------

STAY SAFE ONLINE:

Coordinator	:	Dr Minakshi Tamuli
-------------	---	--------------------

ADMISSION FEE STRUCTURE (RURAL) FOR THE ACADEMIC SESSION 2021-2022
MAYANG ANCHALIK COLLEGE
 Rajamayong, Morigaon, Assam-782411
B. A. Courses

Sl. No	Head	Fees for Degree Course (Arts)
1	Admission	400.00
2	a Tuition (General)	720.00
	b Tuition (Major)	840.00
3	Establishment	600.00
4	a Laboratory (General)	100.00
	b Laboratory (Major)	200.00
5	Electricity	200.00
6	Contingency	200.00
7	University Fee	620.00
8	I Card	50.00
9	Development	500.00
10	Library	200.00
11	Internal Exam	200.00
12	NCC/NSS/Scout	30.00
13	Magazine	150.00
14	Student's Union	100.00
15	Games & Sports	100.00
16	Festival	100.00
17	Co-curricular	100.00
18	Cultural/Music	50.00
19	Debating/Literature	50.00
20	Students Welfare	50.00
21	ICT	100.00
22	Youth Festival/Music	100.00
	Total (General)	Rs. 4720.00
	Total (Major)	Rs. 4940.00

Academic Calendar of Mayang Anchalik College (2024-25)

Months	Working Days	Sundays	Holidays	College Activities
June, 2024	1 3 4 5 6 7 8 10 11 12 13 14 15 19 20 21 22 24 25 26 27 28 29	2, 9, 16, 23, 30	17-18- ID-Uz-Zoha	5 th June World Environment Day Celebration Commencement of 3 rd and 5 th Semester Classes
July, 2024				Summer Vacation
August, 2024	1 2 3 5 6 7 9 10 12 13 14 16 17 19 20 21 22 24 27 28 29 30 31	4, 11, 18, 25	13- College Foundation Day 15-Independence Day 23- Tithi of Sri Madhavdev 26-Janmashtami	Commencement of Odd Semester Classes of 1 st Semester 13 College Foundation Day Fresher's Social
September,2024	2 3 5 6 7 9 10 11 12 13 14 16 17 18 19 20 21 23 24 25 26 27 28 30	1, 8, 15, 22, 29	4- Tithi of Sri Sri Sankardeva	MAC Students Union Election
October, 2024	1 3 4 5 7 8 19 21 22 2 24 25 26 28 29 30	6, 13, 20, 27	2-Gandhi Jayanti 9-18- Durga Puja and Lakshmi Puja, Kati Bihu, Janmutsav of Sri Srimanta Sankardeva 31-Kal Puja	Educational Field Trips Odd Semester Examination Seminar/Workshop
November,2024	2 4 5 6 8 9 11 12 13 14 16 18 19 20 21 22 23 25 26 27 28 29 30	3, 10 17, 24	1- Dipawali 3-Bhatri Dwitiya 7-Chat Puja 15-Guru Nanak's Birth Day 24-Lachit Divas	Odd Semester Examination
December,2024	3 4 5 6 7 9 10 11 12 13 14 16 17 18 19 20 21 23 24 26 27 28 30 31	3 10 17 24 31	2-Asom Divas 25- Christmas Day	End-Semester Break as per GU Academic Calendar
January,2025	1 2 3 4 5 6 8 9 10 11 12 13 15 16 17 18 19 20 22 23 24 25 27 29 30 31	1, 8, 15, 22, 29	2- Asom Divas 25-Christmas	End-Semester Break as per GU Academic Calendar Commencement of Even Semester Classes -Annual College week Festival
February,2025	1 3 4 5 6 7 8 10 11 12 13 14 15 17 18 19 20 21 22 25 27 28	2, 9, 16, 23	2- Saraswati Puja 24- Bir Chilaray Divas 26-Shivratri	Seminar/Workshop
March, 2025	1 3 4 5 6 7 8 10 11 12 13 17 18 19 20 21 22 24 25 26 27 28 29	2, 9, 16, 23, 30	14-15-Dol Jatra 30-31-Id-Ul-Fitre	Seminar/Workshop
April, 2025	1 2 3 4 5 7 8 9 10 11 12 16 17 19 21 22 23 24 25 26 28 29 30	6, 13, 20, 27	13-15 Bohag Bihu 18-Good Bad Friday	Even Semester Sessional Examination
May, 2025	1 2 3 5 6 7 8 9 10 13 14 15 16 17 19 20 21 22 23 24 26 27 28 29 30 31	4, 11, 18, 25	1 May Day 12-Buddha Purnima	Even Semester Examination



**OFFICE OF THE REGISTRAR
GAUHATI UNIVERSITY::GOPINATH BORDOLOI NAGAR::GUWAHATI-781014
HOLIDAY LIST FOR THE PERIOD FROM 1st JANUARY, 2023 TO 31st DECEMBER, 2023
FOR THE CALENDAR YEAR 2023**

(As approved by the Hon'ble Vice-Chancellor on dated. 14.12.2022)

(A) Holidays: Offices & Classes of the University and its affiliated & permitted colleges will remain closed on the following days w.e.f. 1st January 2023 to 31st December, 2023.

Sl. Nos.	Occasions	Month	Date (s)	Day (s) of the week	No. of days
1	Magh Bihu	January	13,14, 15, & 16	Friday, Saturday, Sunday, & Monday	4
2	Gwther Bathou San		24	Tuesday	1
3	Republic Day/ G.U. Foundation Day/ Saraswati Puja,		26	Thursday	1
4	Me-Dum-Me-Phi		31	Tuesday	1
5	Bir Chilarai Divas	February	5	Sunday	1
6	Ali Aye Lingang		15	Wednesday	1
7	Sivaratri		18	Saturday	1
8	Dol Jatra	March	7	Tuesday	1
9	Good Friday	April	7	Friday	1
10	Bohag Bihu		14,15,16	Friday, Saturday, Sunday	3
11	Id-UL-Fitre		22, & 23	Saturday, & Sunday	2
12	May Day	May	1	Monday	1
13	Buddha Purnima	June	5	Friday	1
14	Id-Uz-Zuha		29 & 30	Thursday, & Friday	2
15	Independence Day	August	15	Tuesday	1
16	Tithi of Srimanta Sankardeva		18	Friday	1
17	Tithi of Sri Sri Madhabdeva		4	Monday	1
18	Jannastomi	September	6	Wednesday	1
19	Janmostav of Srimanta Sankardev		25	Monday	1
20	Birthday of Mahatma Gandhi		2	Monday	1
21	Kati Bihu	October	18	Wednesday	1
22	Durga Puja/Lakshmi Puja		20 to 28	Friday to Saturday	9
23	Kali Puja & Dipawali		12 & 13	Sunday & Monday	2
24	Bhatri Dwitiya	November	15	Wednesday	1
25	Chhat Puja		19	Sunday	1
26	Lachit Divas		24	Friday	1
27	Guru Nanak's Birthday		27	Monday	1
28	Asom Divas (Su-ka-Pha Divas)		2	Saturday	1
29	Christmas Day	December	25	Monday	1

(B) Restricted Holidays: Each employee will also be entitled to avail himself/herself of any 3 (three) holidays in the year to be chosen by him/her out of the following list of restricted holidays. The employee(s) intending to avail this holiday should submit application to the concerned Head for approval of the competent authority in advance. Such leave will normally be granted by the leave sanctioning authority except when the presence of the employee(s) is considered necessary due to exigencies of work in the University.

Sl.Nos	Occasions	Month	Date (s)	Day (s) of the week	No. of days
1	New Year's Day	January	1	Sunday	1
2	Silpi Divas		17	Tuesday	1
3	Netaji's Birthday		23	Monday	1
4	Khring Khring Baithow Puja	February	27	Monday	1
5	Shab-E- Barat	March	8	Wednesday	1
6	Mahabir Jayanti	April	4	Tuesday	1
7	Tithi of Damodar Dev		20	Thursday	1
8	Sati Sadhani Divas		21	Friday	1
9	Tithi of Gopal Dev	May	25	Tuesday	1
10	Tithi of Hari Dev		19	Friday	1
11	Jannotsab of Sri Sri Madhab Dev		5	Monday	1
12	Death of Anniversary Bishnu Prasad Rabha	June	20	Tuesday	1
13	Ambubasi Nibriti	July			1
14	Muharram		29	Saturday	1
15	Biswakarma Puja		17	Sunday	1
16	Fateha-E-Dwaz Daham	December	28	Thursday	1
17	Martyr's Day		10	Sunday	1
18	Christmas Eve		24	Sunday	1

- Note: 1) If any Holidays for occasions do not fall on the days notified, necessary notification, changing the date will be issued in due course.
2) Additional holidays further to the above will be applicable as when declared by the University Administration.
3) Summer/Winter break will be as specified in the Academic Calendar.
4) Any other days as may be declared by the State Govt./Dist. Admn. Under Section 25 of the Negotiable Instruments Act, 1888 (XXIV of 1881) as holidays will be observed.
5) Silpi Divas to be celebrated on 17th Jan, 2023 from 2 pm.
6) The exact date of Ambubasi Nibriti will depend on the next Assamese new calendar which is not available now.

Memo No. GU/G/Holiday/8/2022/ 2618 - 2717

Date. 15-12-2022

Copy forwarded for information and necessary action to:-

- All Heads of the Teaching Departments, Gauhati University.
- All Heads of the Administrative Departments, Gauhati University.
- The Principal, University Law College, Gauhati University.
- The Principal of all Affiliated Colleges..
- The Registrars of all Indian Universities.
- The Secretary, Board of Secondary Education, Assam, Guwahati - 21.
- The Secretary, Assam Higher Secondary Education Council, Guwahati - 21.
- The Secretary to the Governor of Assam, Raj Bhawan, Guwahati - 1.
- The Secretary to the Govt. of Assam, Education Department, Guwahati - 6.
- The Director of Higher Education, Assam, Guwahati - 19.
- The Director of Medical Education, Assam, Dispur, Guwahati - 6.
- The Secretary, University Grant Commission, Bahadur Shah Zafar Marg, New Delhi - 110002.
- The Director of Technical Education, Assam, Guwahati - 19.
- The Secretary, Association of Indian Universities, A.I.U., 16 Kotla Marg, New Delhi-110002.
- The Secretary to the Vice-Chancellor, Gauhati University.
- The Secretary to the Registrar, Gauhati University.
- The Deputy Registrar, Gauhati University.
- University Website.

Registrar
Gauhati University



Latitude: 26.25432
Longitude: 92.0462
Elevation: 35.22m
Accuracy: 2.31m
Time: 09-09-2023 13:04
Note: Youth Conclave



Latitude: 26.253497
Longitude: 92.046513
Elevation: 57.12m
Accuracy: 1.5m
Time: 17-09-2023 10:12
Note: Amrit Bikhya Andolan



Latitude: 26.254298
Longitude: 92.046732
Elevation: 88.02m
Accuracy: 5.5m
Time: 04-02-2024 14:39
Note: PM Vishwakarma



Latitude: 26.254317
Longitude: 92.046187
Elevation: 25.72m
Accuracy: 2.5m
Time: 23-09-2023 14:46
Note: Freshmen Social



Latitude: 26.25428
Longitude: 92.046313
Elevation: 56.02m
Accuracy: 2.5m
Time: 14-11-2023 11:12
Note: departmental seminar



Latitude: 26.254323
Longitude: 92.046438
Elevation: 35.42m
Accuracy: 3.8m
Time: 26-02-2024 12:41
Note: PM DAKSH

